



MITSUBISHI ELECTRIC AUTOMATION (THAILAND) CO., LTD.

Bang-Chan Industrial Estate No. 111 Moo 4, Serithai Rd., T.Kannayao, A.Kannayao, BKK 10230 Thailand
 Tel: (66) 2517-1326, (66) 2919-9873 Fax: (66) 2517-1328 URL: www.meath-co.com E-mail: support@meath.co.th

บริษัท มิตซูบิชิ อิเล็กทริก ออโตเมชั่น (ประเทศไทย) จำกัด

นิติบุคคลสาขารวมบางชิ้น เลขที่ 111 หมู่ 4 ถนนเสรีไทย แขวงคันนายาว เขตคันนายาว กทม. 10230
 โทรศัพท์: (66) 2517-1326, (66) 2919-9873 โทรสาร: (66) 2517-1328 URL: www.meath-co.com E-mail: support@meath.co.th

MOTOR SPECIFICATION SHEET

MODEL : SF-Q 30HP 4P (HT)

USED FOR : STANDARD

DESCRIPTION	DETAIL		
PHASE	3		
MODEL NAME	SF-Q		
RATED OUTPUT, HP (kW)	30 (22)		
POLE	4		
CODE	MEATH CODE : 1M002F-402200Q-MJO		
OUTLINE DRAWING NO.	ONM34O304-D		
RATED VOLTAGE (V)	380	415	
RATED FREQUENCY (Hz)	50	50	
RATED CURRENT (A)	44.2	43.7	
RATED SPEED (min ⁻¹)	1470	1475	
RATED EFFICIENCY (%)	90.2	90.0	
EFFICIENCY CLASS	IE1		
THERMAL CLASS	155(F)		
RATING	S1 (CONTINUOUS)		
ENCLOSURE CONSTRUCTION	TOTALLY ENCLOSED FAN COOLED		
DEGREES OF PROTECTION	IP55		
METHOD OF COOLING	IC411		
FRAME NO.	180M		
WEIGHT (kg)	213		
STANDARD	IEC 60034-1, IEC 60034-30-1		
INSTALLATION	FOOT MOUNTED		
ROTATION	CCW (VIEWED FROM SHAFT END)		
BEARING	LOAD SIDE	: 6311ZZ	
	OPPOSITE SIDE	: 6310ZZ	
BEARING GREASE	UREA GREASE		
NOISE (dB.A)	82		
VIBRATION	V15		
CIRCUMSTANCE CONDITION	AMBIENT TEMPERATURE	: -20 ~ +40°C	
	AMBIENT HUMIDITY	: 95%RH OR LESS	
	ABOVE SEA LEVEL	: 1000m OR LESS	
	ENVIRONMENT	: NO BURSTING/EROSIVE GAS OR VAPOR	
COLOR	MUNSELL N1.5 (BLACK)		
TERMINAL BOX	NO. OF LEAD WIRES	: 6	
	SOURCE CONNECTION	: LEAD WIRES	
SHAFT SWING	≤0.05mm		
MATERIAL	FRAME	: CAST IRON	
	BRACKET	: CAST IRON	
	SHAFT	: CARBON STEEL	
	STATOR CORE	: ELECTRICAL STEEL	
	WIRE	: ENAMELLED COPPER MAGNET WIRE	
	ROTOR CORE	: ELECTRICAL STEEL	
	CONDUCTOR	: ALUMINIUM	
	TERMINAL BOX	: STEEL PLATE	
	PAINTING	: POLYURETHANE RESIN	
APPLIED ITEM	INSULATION REINFORCEMENT FOR INVERTER DRIVE		
PRODUCTION COUNTRY	THAILAND		

Specifications subject to change without notice.

SPECIFICATION SHEET NO.				
SS-N-3128-C				

MODEL **SF-Q** THREE PHASE INDUCTION MOTOR OUTLINE DRAWING

TOTALLY ENCLOSED FAN COOLED
 DEGREES OF PROTECTION IP55
 DUST & WATER JET PROOF

CUSTOMER _____
 USER _____
 FOR _____
 CUSTOMER'S ORDER NO. _____
 QUANTITY _____
 MFG. ORDER NO. _____

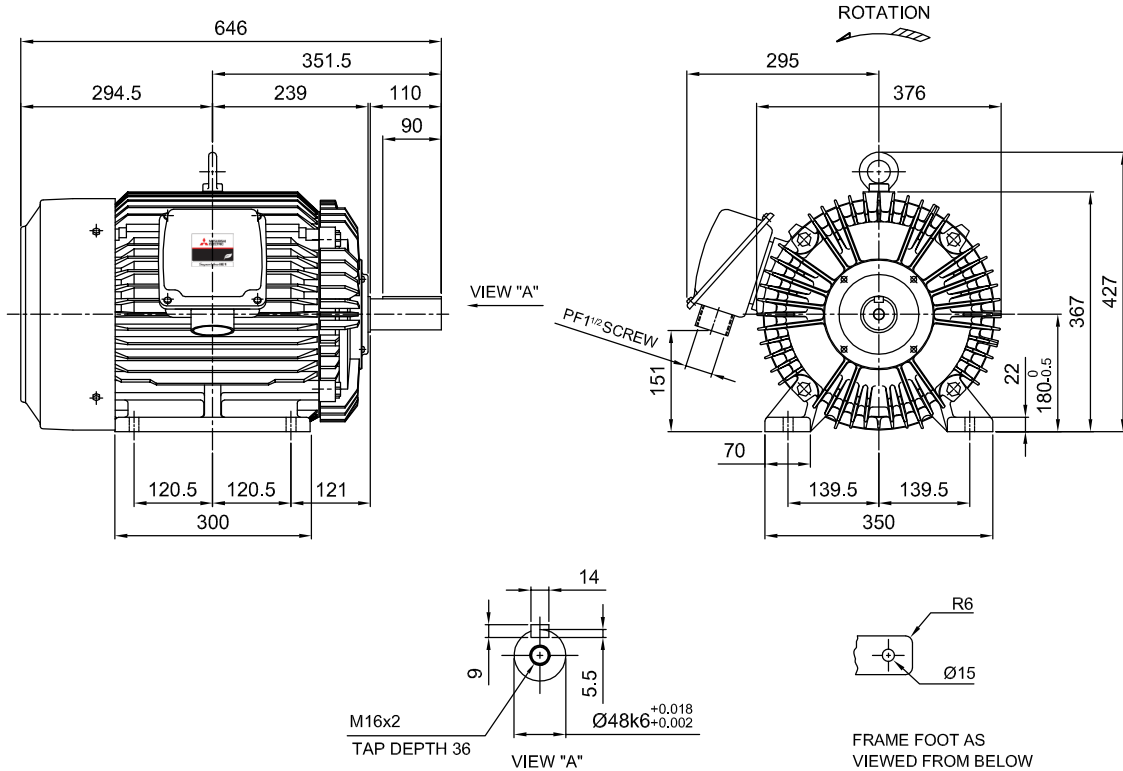

YOUR ORDER	FRAME SIZE	RATING	TH. CLASS	AMB. TEMP.	BEARINGS		COLOR	DIRECTION OF ROTATION (VIEWED FROM SHAFT END)	NO. OF LEAD WIRES	REMARKS
					LOAD SIDE	OPP. SIDE				
	180M	S1 (CONT.)	155(F)	40°C	6311ZZ	6310ZZ	BLACK (MUNSELL N1.5)	CCW	6	

YOUR ORDER	OUTPUT		POLES	VOLTS	HERTZ	AMP.	RPM	IE CODE-RATED EFF.	REMARKS
	HP	KW							
	30	22	2	380/415	50	42.7/40.2	2930/2945	IE1-90.2%/91.0%	HT
	25	18.5	4	380/415	50	37.6/37.4	1470/1480	IE1-89.9%/89.8%	HT
	30	22	4	380/415	50	44.2/43.7	1470/1475	IE1-90.2%/90.0%	HT
	20	15	6	380/415	50	32.5/32.1	975/980	IE1-88.5%/88.3%	HT
	30	22	2	220/380/415	50	74.0/42.7/39.6	2920/2920/2940	IE1-89.9%/89.9%/90.2%	LT
	25	18.5	4	220/380/415	50	66.1/38.2/39.2	1475/1475/1480	IE1-89.9%/89.9%/89.3%	LT
	30	22	4	220/380/415	50	76.6/44.2/43.9	1475/1475/1480	IE1-90.2%/90.2%/90.0%	LT
	20	15	6	220/380/415	50	56.3/32.5/32.1	975/975/980	IE1-89.0%/89.0%/88.3%	LT

MITSUBISHI ELECTRIC AUTOMATION (THAILAND) CO., LTD.

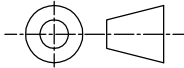
 DIMENSION IN mm. SCALE : NTS	OUTLINE DRAWING NO.		REV.
	O N M 3 4 0 3 0 4		